



All about
natural
**VERTICAL
GARDENS**

INDEX

PIXEL GARDEN	06
ALU LINE	20
SIMPLE LINE	40
OFFICE LINE	60
PREMIUM LINE	70
WATER FILLING STATION	84
MY LITTLE HOME GARDEN	96
DECORATIVE POTS	114
ACOUSTIC BOXES	126
LAWN LATTICE	142

A large, illuminated sign for Singapore is set against a lush, green living wall. The sign features the word "Singapore" in Arabic script, "سنغافورة", in white with a blue outline, positioned above the word "SINGAPORE" in large, bold, white capital letters with a blue outline. The background is a dense wall of various green plants, including ferns and broad-leafed species. The scene is lit with warm, ambient lighting, suggesting an evening or night setting.

سنغافورة
SINGAPORE



... WHO WE ARE?

Garden Spot is a Polish manufacturer of modular vertical gardens system Pixel Garden. We have been dynamically operating in the horticulture industry since 2008. We use our products in order to promote the idea of **GREEN WALLS**, which are more and more often used in both commercial and individual construction.

The products we offer set new standards in space design and bring freshness, color and health to the environment. Vertical gardens are interesting and unique way of growing plants in apartments, office spaces and public institutions.

Vertical gardens allow not only to increase the area of biological active surface without the need to find additional space, but also to bring nature closer and integrate it into an everyday room and to enjoy its presence.



more info: gardenspot.eu







PIXEL GARDEN SYSTEM



Idea of the system	8
Think green	10
Technology	11
Irrigation	12
PG14 model	14
PG09 model	16



... PIXEL GARDEN SYSTEM

Pixel Garden is modular system to build vertical gardens dedicated for living plants. The system is made of polypropylene which is manufactured from 100% recycled materials. Due to high resistance on UV radiation the system can be used both in indoor and outdoor environment.

The Pixel Garden module consists of case, two pots and connector. In our offer you can find:

- **Pixel Garden PG14** with a standard pot diameter of 14 cm, allows you to compose a vertical garden both in a small area in an apartment and an extent area on the facade of the building.
- **Pixel Garden PG09** with pots of diameter of 9 cm which we recommend to create very tiny green walls or in order to grow the herbs and vegetables.

The advantage of the Pixel Garden system is the possibility of removing the pot with a plant from the vertical garden, which facilitates, among others, changing the plant arrangement, replacing plants and carrying out plant care treatments.





PIXEL GARDEN SYSTEM ...

Modules are available in two colors light grey and black therefore they blend in easily with any interior.

Modules are assembled to the wall individually what allows you to create a vertical garden of any width and height. Each module is equipped with an integrated overflow system what allows for complete irrigation of the vertical garden by supplying water only to the highest row of modules.

The technology of Pixel Garden PG14 and PG09 modules allows you to irrigate the garden manually, semi-automatically and automatically.

All our products are certified, have UV resistance, strength and temperature resistance tests. PG14 modules also have a certificate confirming compliance with fire protection requirements.

more info: gardenspot.eu/pixel-garden



Think green

... Benefits of vertical gardens



Air purification
and dust reduction



Noise level reduction



Heat reduction and
energy cost reduction



Water management



Biodiversity



Aesthetics



More green spaces



Health and well-being

... Testing of Pixels



UV resistance

(standards: PN-EN ISO 4892-2:2013-6)



Tensile strength

(standards: PN-EN ISO 527-1:2012,
PN-EN ISO 527-2:2012)



Vicat softening point

(standards: PN-EN 306:2014-02)



Shear strength

(wg: ASTM D 732-17)

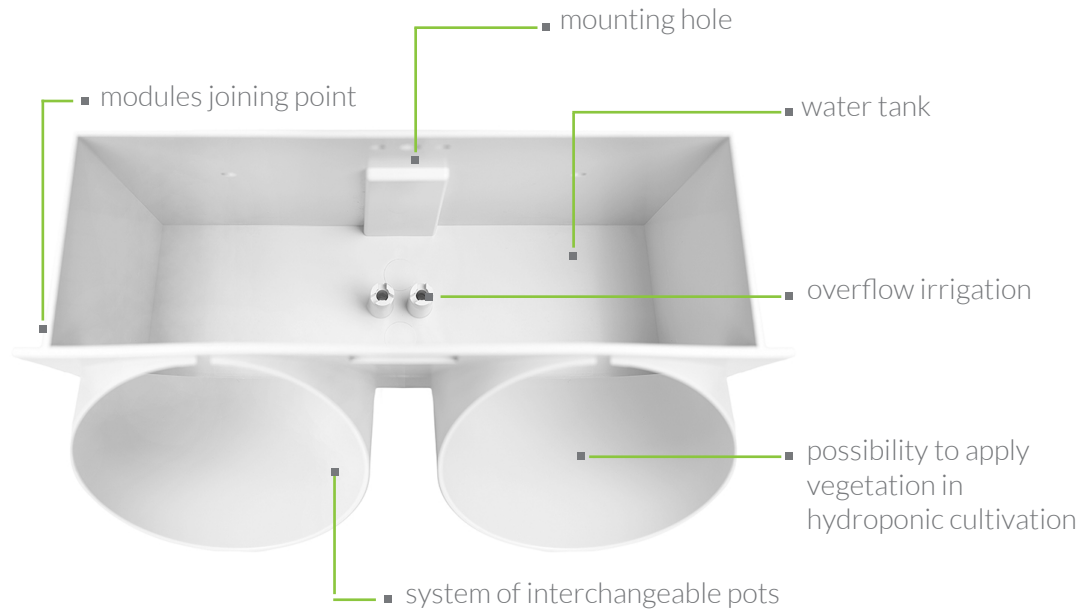
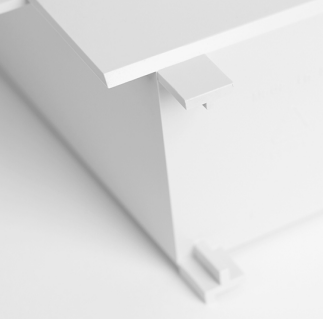

... PIXEL GARDEN irrigation

The system is designed with a very innovative approach where the traditional way of irrigation is not required.

The water is vertically transferred from one container to another tanks to gravity, therefore, regardless of height, it only requires a single irrigation supply on the top row of any panel.

ALTERNATIVE IRRIGATION :



PORTABLE

irrigation system: water filling station



AUTOMATIC

irrigation system



GARDEN COUPLER

irrigation system



MANUAL

irrigation system





Pixel PG14

14



PIXEL GARDEN

Technical data

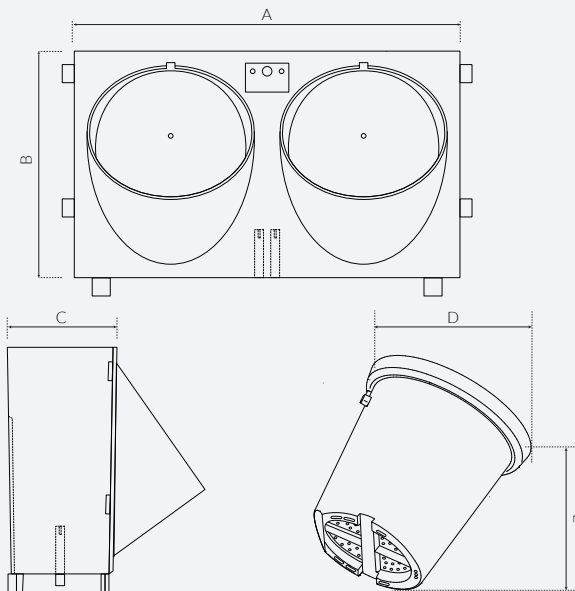

Dimensions

A: 302 mm B: 188 mm C: 92 mm D: 144 mm E: 152 mm *dimensions: +/- 3 mm

Specification



PP PE



Diameter
of the pot - 14 cm



18 pcs
per 1 m²



black | white



0,70 kg



0,70 L



DIGITAIN

Pixel PG09

16



PIXEL GARDEN

Technical data

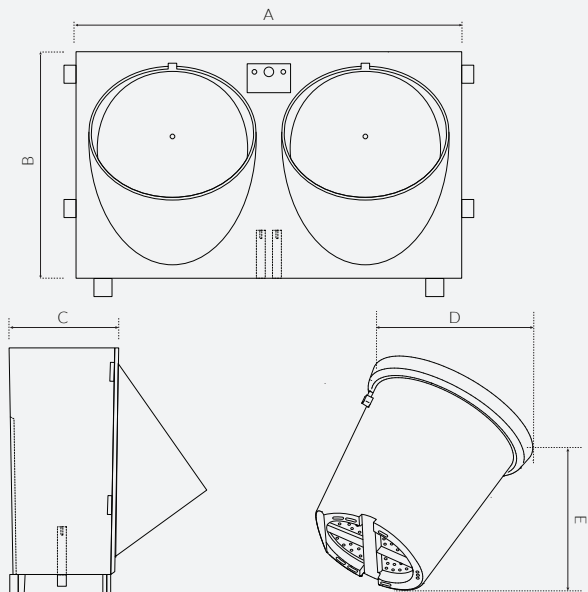

Dimensions

A: 199 mm B: 123 mm C: 60 mm D: 90 mm E: 89 mm *dimensions: +/- 3 mm

Specification



PP PE



Diameter
of the pot - 9 cm



40 pcs
per 1 m²



black | white



0,25 kg



0,35 L





WYCOLA.UK







ALU LINE

Alu Line idea	22
Hanging vertical frames	24
Mobile vertical frames	26
Standing vertical frames	34



... ALU LINE

Alu Line is the series of aluminum frames with installed Pixel Garden system.

Hanging frames are easily attached to the wall. Vertical gardens in the wall version can be designed directly next to the wall without the need for assembly. The advantage of the mobile product is the use of the wheel system, which allows it to be easily and quickly moved and to change the interior arrangement.

Alu Line products are irrigated through an overflow system, i.e. manually or semi-automatically using an irrigation station.





ALU LINE ...

In our offer you can find also double sided option which can be used as the fences or screens in office and restaurant spaces.

A series of products available in aluminum frames launched a new Premium line, i.e. a combination of a vertical garden with a mobile irrigation station, available in our Alu Line Premium line catalog.



more info: gardenspot.eu/living-pictures

... ALF2/3PG14 | one-sided, hanging frame



24

... Technical data

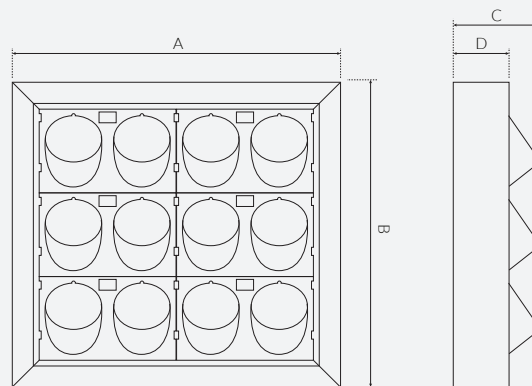

Dimensions

A: 720 mm

B: 680 mm

C: 220 mm

D: 120 mm

*dimensions: +/- 3 mm

Specification



steel | PP PE



PG14



6 pcs



black | white



20 kg

Irrigation system



manual



... ALM3/9PG14 | one-sided, mobile frame



26

... ALU LINE

... Technical data

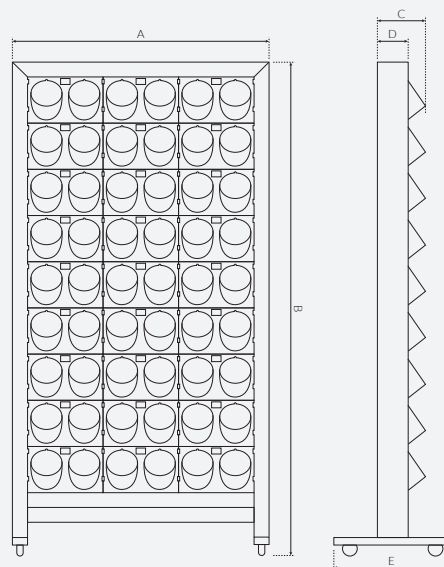

Dimensions

A: 1020 mm B: 2060 mm C: 220 mm D: 120 mm E: 530 mm

Specification

*dimensions: +/- 3 mm

steel | PP PE PG14 27 pcs black | white 70 kg

Irrigation system

manual garden hose automatic water filling station



... ALM4/9PG14 | one-sided, mobile frame

28



... ALU LINE

... Technical data

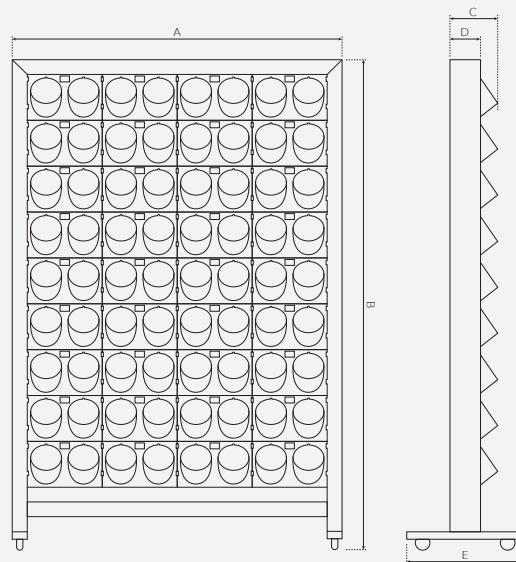





Dimensions

A: 1322 mm B: 2060 mm C: 220 mm D: 120 mm E: 530 mm

Specification

*dimensions: +/- 3 mm

-  steel | PP PE
-  PG14
-  36 pcs
-  black | white
-  90 kg

Irrigation system

-  manual
-  garden hose
-  automatic
-  water filling station



... ALM2.3/9PG14 | two-sided, mobile frame

30



... ALU LINE

... Technical data

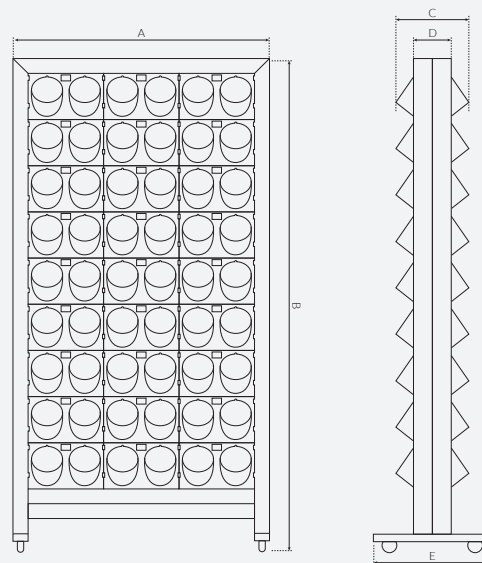





Dimensions

A: 1020 mm B: 2060 mm C: 350 mm D: 200 mm E: 530 mm

Specification

*dimensions: +/- 3 mm

 steel | PP PE  PG14  54 pcs  black | white  90 kg

Irrigation system

 manual  garden hose  automatic  water filling station



... ALM2.4/9PG14 | two-sided, mobile frame

32



... ALU LINE

... Technical data

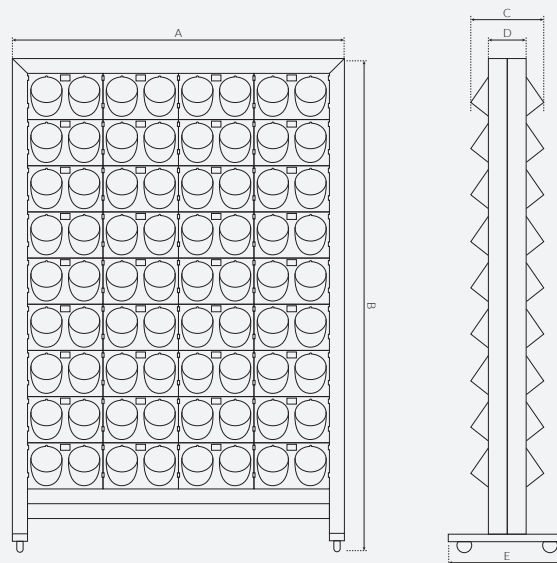





Dimensions

A: 1322 mm B: 2060 mm C: 350 mm D: 200 mm E: 530 mm

Specification

*dimensions: +/- 3 mm

 steel | PP PE  PG14  72 pcs  black | white  120 kg

Irrigation system

 manual  garden hose  automatic  water filling station



... ALL2/9PG14 | one-sided, standing frame

34



... Technical data

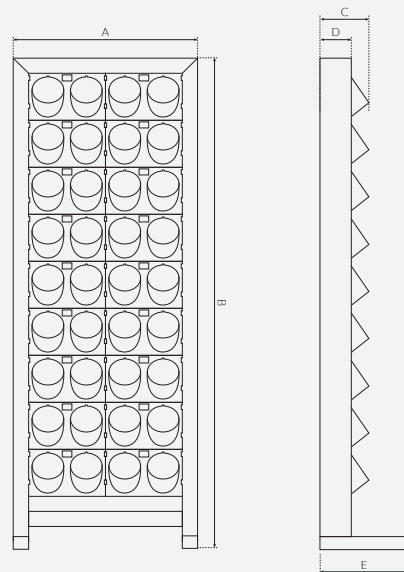





Dimensions

A: 718 mm B: 1990 mm C: 220 mm D: 120 mm E: 360 mm

Specification

*dimensions: +/- 3 mm

 steel | PP PE  PG14  18 pcs  black | white  50 kg

Irrigation system

 manual  garden hose  automatic  water filling station



GARDEN
spot

ALU LINE

... ALL3/9PG14 | one-sided, standing frame



36

... ALU LINE

... Technical data

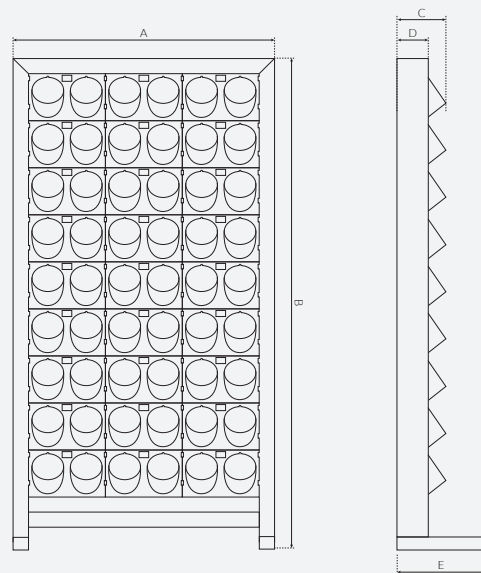

Dimensions

A: 1020 mm B: 1990 mm C: 220 mm D: 120 mm E: 360 mm

Specification

*dimensions: +/- 3 mm



steel | PP PE



PG14



27 pcs



black | white



70 kg

Irrigation system



manual



garden hose



automatic



water filling station









SIMPLE LINE

Simple Line idea	42
Hanging vertical frames	44
Mobile vertical frames	46
Standing vertical frames	54



... SIMPLE LINE

Simple Line is a series of steel frames based on Pixel Garden modules, designed for the needs of customers looking for unique solutions at an attractive price. Green walls framed with pictures, painted in any color from the RAL palette, provide a unique variety of space.

Any configuration of green hanging, standing or mobile walls allows you to present the interior in a simple and inimitable way at the same time.

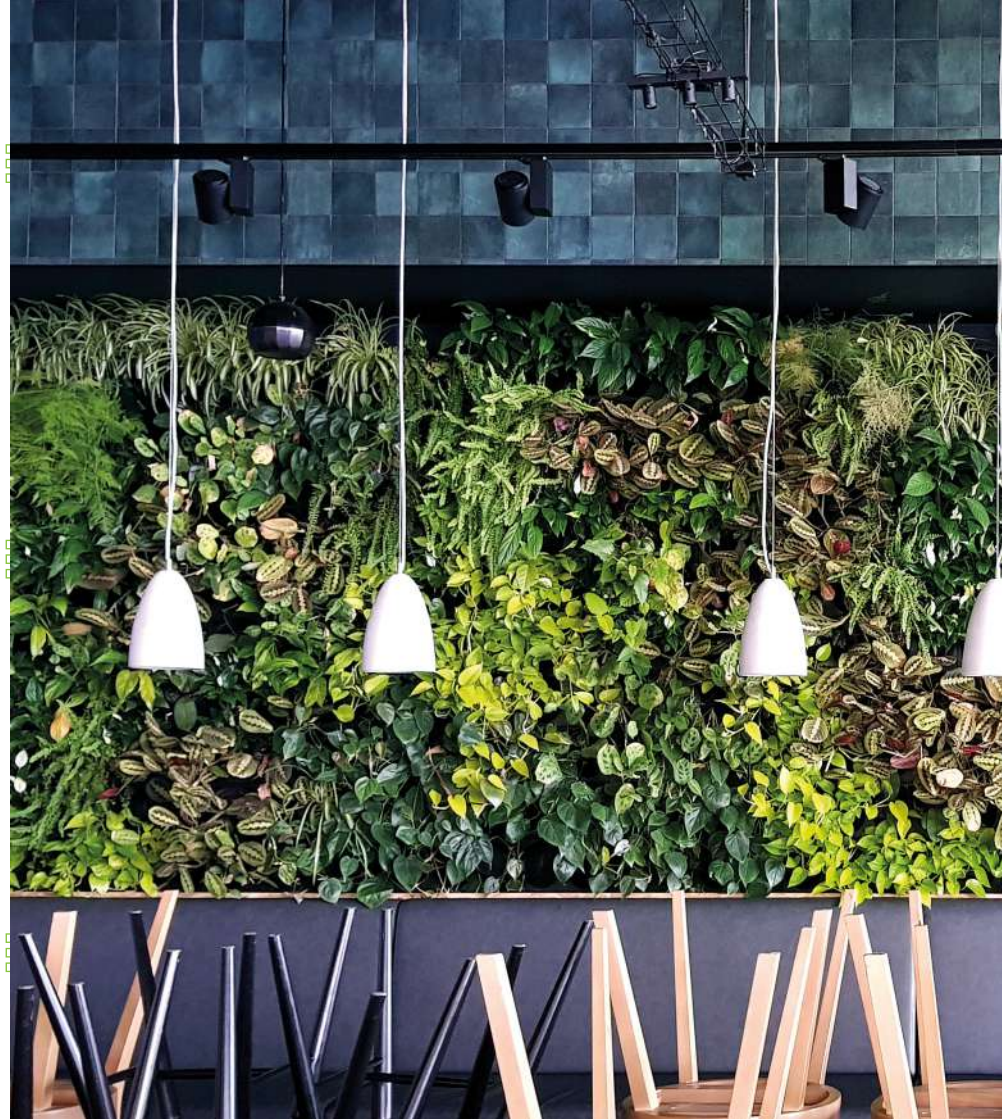



SIMPLE LINE ...

Simple Line products are irrigated manually through an overflow system or semi-automatically using the Water Filling Station.

At the customer's request we can customize the size of Simple Line products.



more info: gardenspot.eu/living-pictures

STF3/4PG09 | one-sided, hanging frame

44



Technical data

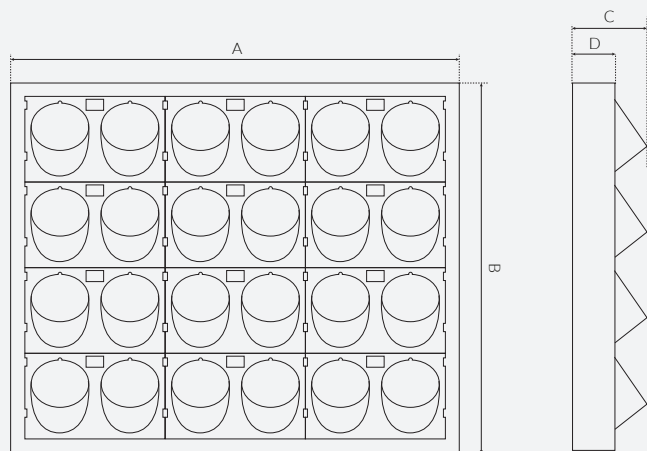





Dimensions

A: 617 mm B: 512 mm C: 140 mm D: 80 mm

*dimensions: +/- 3 mm

Specification

 steel | PP PE  PG09  12 pcs  black | white  9 kg

Irrigation system

manual



SIMPLE LINE

... STM3/9PG14 | one-sided, mobile frame



46

... SIMPLE LINE

... Technical data

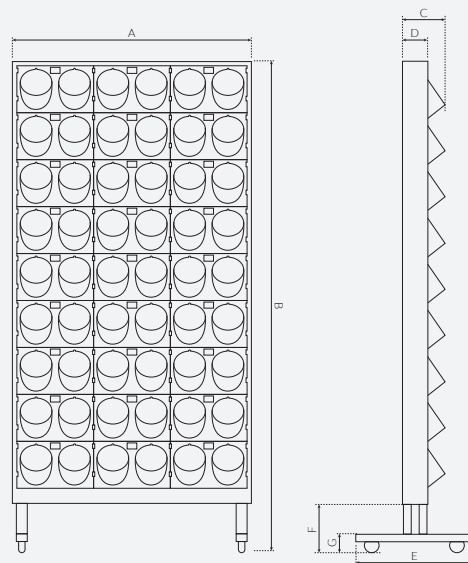





Dimensions

A: 925 mm B: 1980 mm C: 210 mm D: 115 mm E: 470 mm F: 230 mm G: 125 mm

Specification

*dimensions: +/- 3 mm

 steel | PP PE  PG14  27 pcs  black | white  50 kg

Irrigation system

 manual  garden hose  automatic  water filling station



SIMPLE LINE

... STM4/9PG14 | one-sided, mobile frame



48

... SIMPLE LINE

... Technical data

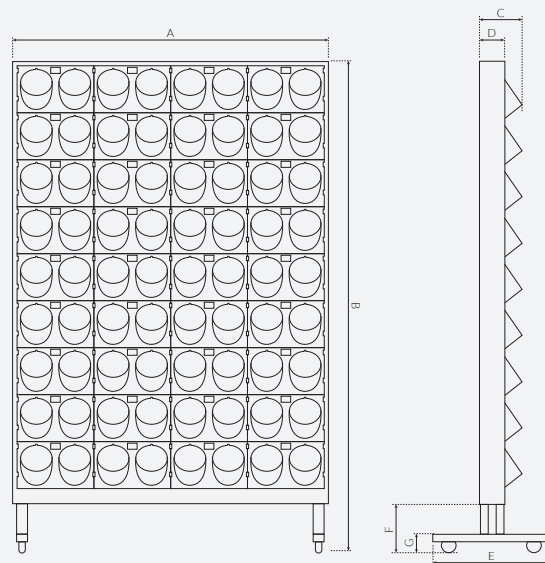





Dimensions

A: 1230 mm B: 1980 mm C: 210 mm D: 115mm E: 470 mm F: 230 mm G: 125 mm

Specification

*dimensions: +/- 3 mm

 steel | PP PE  PG14  36 pcs  black | white  65 kg

Irrigation system

 manual  garden hose  automatic  water filling station



... STM2.3/9PG14 | two-sided, mobile frame



50

... SIMPLE LINE

... Technical data

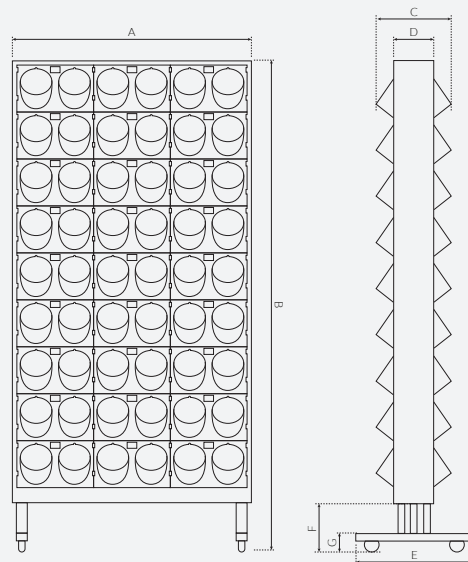





Dimensions

A: 925 mm B: 1980 mm C: 238 mm D: 200 mm E: 425 mm F: 230 mm G: 125 mm

Specification

*dimensions: +/- 3 mm

 steel | PP PE  PG14  54 pcs  black | white  90 kg

Irrigation system

 manual  garden hose  automatic  water filling station



... STM2.4/9PG14 | two-sided, mobile frame



52

... SIMPLE LINE

... Technical data

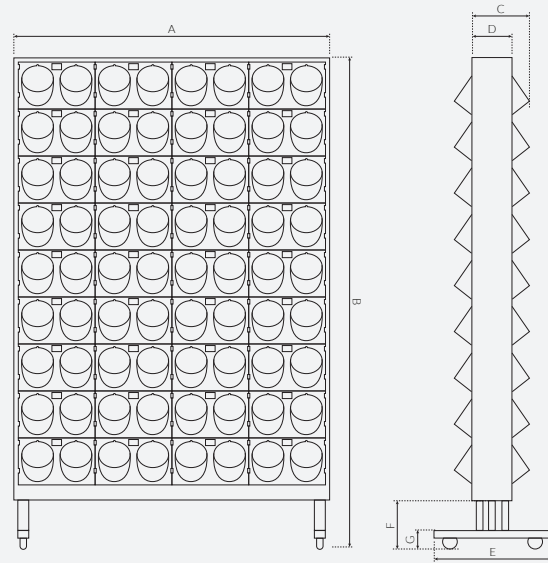

Dimensions

A: 1230 mm B: 1980 mm C: 238 mm D: 200 mm E: 425 mm F: 230 mm G: 125 mm

Specification

*dimensions: +/- 3 mm



steel | PP PE



PG14



72 pcs



black | white



100 kg

Irrigation system



manual



garden hose



automatic



water filling station



SIMPLE LINE

... STL2/9PG14 | one-sided, standing frame

54



... SIMPLE LINE

... Technical data

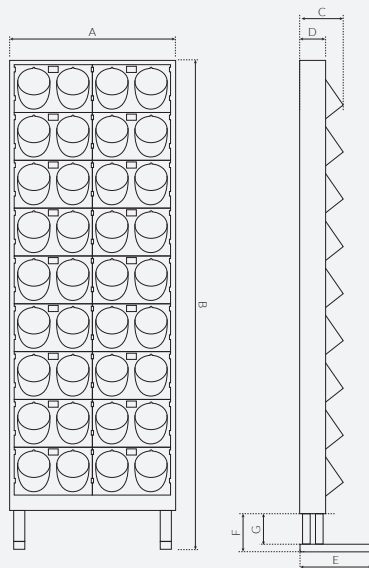





Dimensions

A: 625mm B: 1910 mm C: 210 mm D: 115 mm E: 320 mm F: 120 mm G: 90 mm

Specification

*dimensions: +/- 3 mm

 steel | PP PE  PG14  18 pcs  black | white  40 kg

Irrigation system

 manual  garden hose  automatic  water filling station



... STL3/9PG14 | one-sided, standing frame



56

... SIMPLE LINE

... Technical data

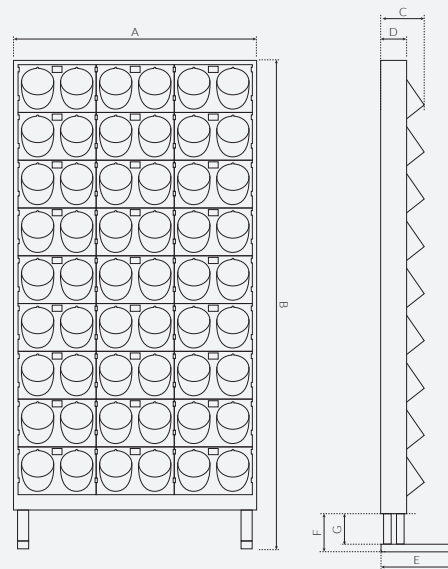

Dimensions

A: 915 mm B: 1910 mm C: 210 mm D: 115 mm E: 320 mm F: 120 mm G: 90 mm

Specification

*dimensions: +/- 3 mm



steel | PP PE



PG14



36 pcs



black | white



48 kg

Irrigation system



manual



garden hose



automatic



water filling station







SIMPLE LINE



OFFICE LINE

Whiteboard Wall — 62

Acoustic Wall — 64



... WHITEBOARD WALL

A green wall with a dry-wipe magnetic board is the new Office Line product by Garden Spot.

Whiteboard Wall is the perfect product for commercial spaces. It combines functional and aesthetic advantages. The dry erase magnetic board is ideal for a conference room or corporate open space. A vertical garden installed on the other side is a solution that will fill the space with greenery, moisten the air and create perfect conditions for work. Choose your own side of the Acoustic Wall.

Whiteboard Wall is available in two basic colors: white and black. Irrigation of the vertical garden takes place through the built-in integrated overflow system.

The perfect complement to the Whiteboard Wall are Acoustic Wall and Water Wall Premium.





... WTB4/9PG14 | two-sided



70

... OFFICE LINE

... Technical data

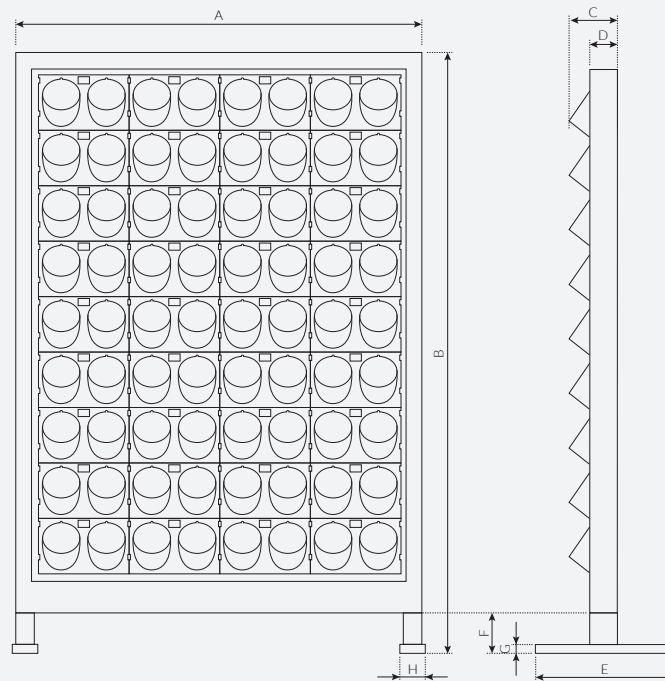





Dimensions

A: 1325 mm B: 1995 mm C: 200 mm D: 120 mm E: 510mm
 F: 140 mm G: 50 mm H: 100 mm

*dimensions: +/- 3 mm

Specification

- 
 stainless steel
aluminium
PP PE
- 
 PG14
- 
 36 pcs
- 
 black | white
black-white mix
- 
 90 kg

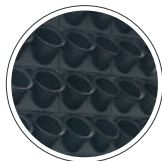

Vertical garden consisting of 36 Pixel Garden modules that can accommodate 72 plants (1 module = 2 pots).



The product is available in various combinations of black and white.



The board is made of high-quality, 2 mm thick, white lacquered metal sheet.



A refined, aluminum structure of high strength and high aesthetic values.



Overflow, integrated irrigation system in several configuration options.

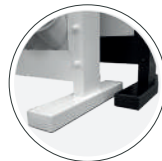

Specially designed new shape of the legs, ensuring firm support and safety.



Smooth, scratch-resistant surface with magnetic properties.



Easy maintenance. Wiping with a dry magnetic sponge and washing with a blackboard cleaner.



Modules made of recycled plastic in two sizes and colours.



Many possibilities of use in commercial and educational spaces.



The possibility of any selection of accessories: pens, magnets or markers.



Possibility of any arrangement of ornamental plants, herbs or vegetables.

... WHITEBOARD WALL

The green wall with acoustic foams is the new Office Line product by Garden Spot.

The Acoustic Wall is a product for commercial spaces that combines a soundproofing and aesthetic function. Acoustic foams are a sound-absorbing element. Spaces separated by the Acoustic Wall, gain an aesthetic composition of foams on one side, creating an atmosphere of confidentiality, on the other side of the wall, the vertical garden fills the space with greenery, moisturizes the air and creates perfect conditions for work and meetings. Choose your own side of the Acoustic Wall.

The Acoustic Wall is available in two basic colors: white and black. Irrigation of the vertical garden takes place through the built-in integrated over-flow system.

The perfect complement to the Acoustic Wall are Whiteboard Wall and Water Wall Premium.





... **WTB4/9PG14** | two-sided

70



... Technical data

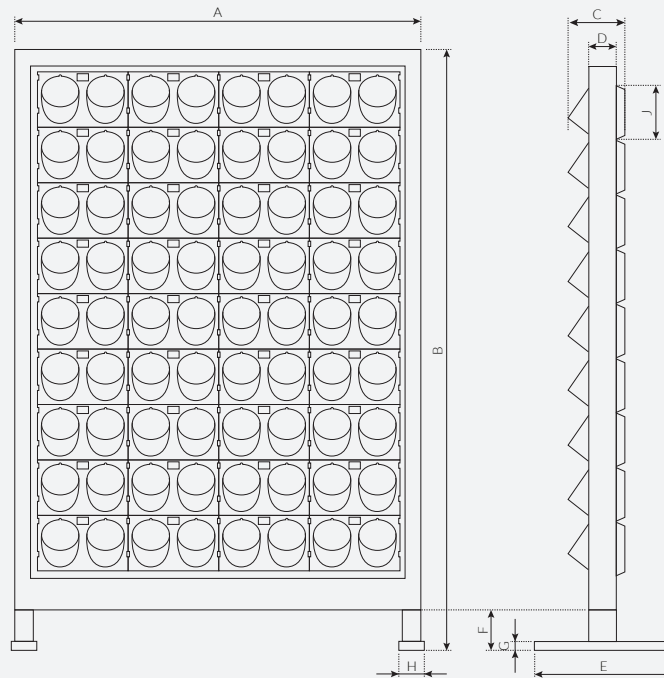

Dimensions

Acoustic panel: 305x190 mm

A: 1325 mm B: 1995 mm C: 230 mm D: 120 mm E: 510mm
 F: 140 mm G: 50 mm H: 100 mm J: 190 mm

*dimensions: +/- 3 mm

Specification



 stainless steel
 aluminium
 PP PE

 PG14

 36 pcs

 black | white
 black-white mix

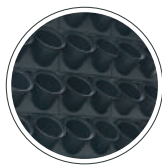
 90 kg



Vertical garden consisting of 36 Pixel Garden modules that can accommodate 72 plants (1 module = 2 pots).



The product is available in various combinations of black and white.



36 acoustic panels absorbing sounds in the medium and high frequency range.



A refined, aluminum structure of high strength and high aesthetic values.



Overflow, integrated irrigation system in several configuration options.

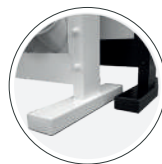

Specially designed new shape of the legs, ensuring firm support and safety.



The properties of reducing the reverberation time and minimizing standing waves, which significantly improves the sound in the environment.



Many possibilities of use in offices, call-centers, rooms and wherever sound quality plays an important role.



Modules made of recycled plastic in two sizes and colours.

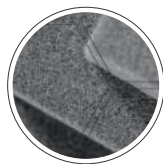

Uniform cell structure. High resistance of panels to discoloration and mechanical damage.

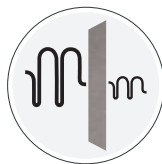

The foams have certificates confirming the properties of limited flammability, slow-burning, as well as hygienic certificates and acoustic tests.

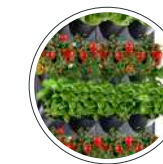

Possibility of any arrangement of ornamental plants, herbs or vegetables.



PREMIUM LINE



Premium Line idea	62
Green Wall Premium	64
Water Wall Premium	68



... PREMIUM LINE

Premium Line products are the flagship Garden Spot projects that are synonymous with high quality. They were designed with particular attention to details using the best materials available on the market. The line consists of the innovative version of the mobile wall Alu Line Premium and Water Wall Premium made of aluminum and stainless steel.

62

Alu Line Premium is double sided mobile green wall based on Pixel Garden. The base of the product is hidden water reservoir on wheels what makes it easy to move. Another advantage of products is the LED lightning installed along the glass panel and the decorative lava stones or snow-white Greek stones.

Premium Line was created for the most demanding customers. The products are available in several color variants.

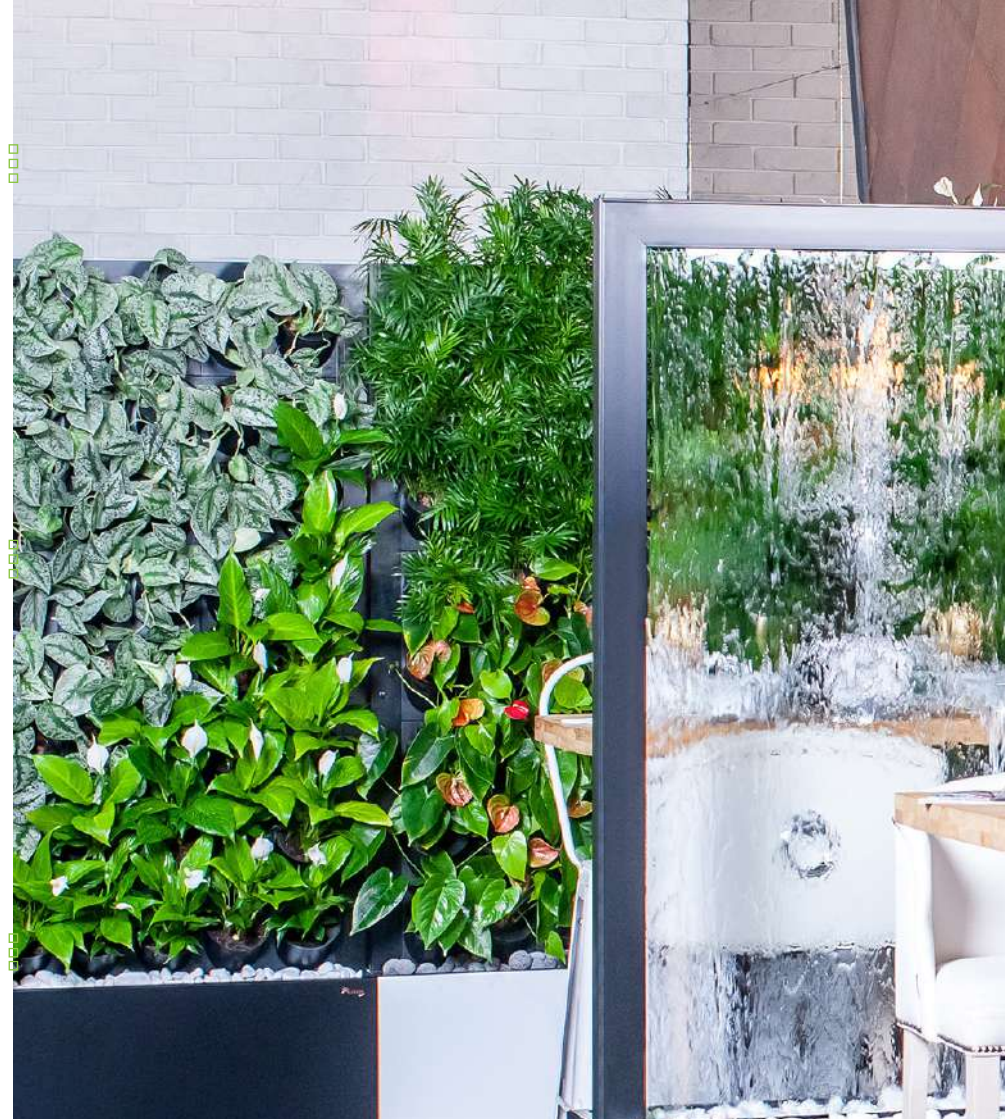





PREMIUM Line products are the flagship Garden Spot projects that are synonymous with **high quality**.

Alu Line Premium green wall

was developed by Polish designers with a view to be used in prestigious and luxurious facilities. It is a perfect idea for finishing the space. Greenery has positive impact on human's well-being – plants increase air humidity and introduce beneficial microclimate. Mobility gives an asset of changable arrangement in interiors such as houses, shopping malls or offices of big companies.



more info:
gardenspot.eu/water-green-wall-premium

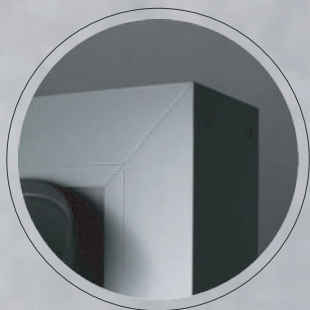

Refined details

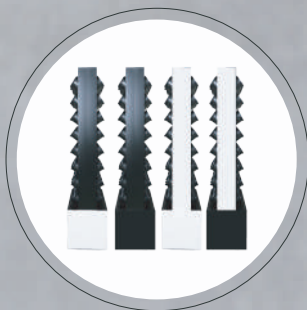

Available in black
and white combination

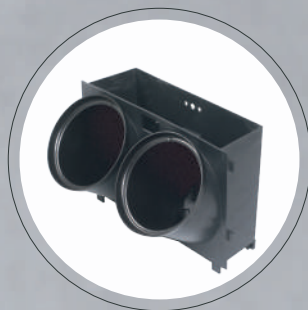

Modular
Pixel Garden System



Natural stones
in two colors



Automatic closed
circuit irrigation

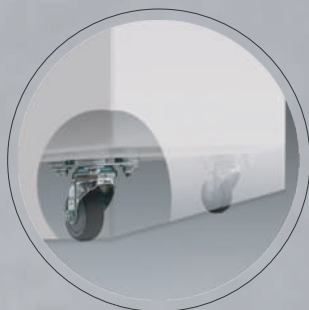

Hidden mobile
wheels



Perfect in combination
with a water wall

... ALMP2.3/8PG14 | two-sided, mobile wall



66

... PREMIUM LINE

... Technical data

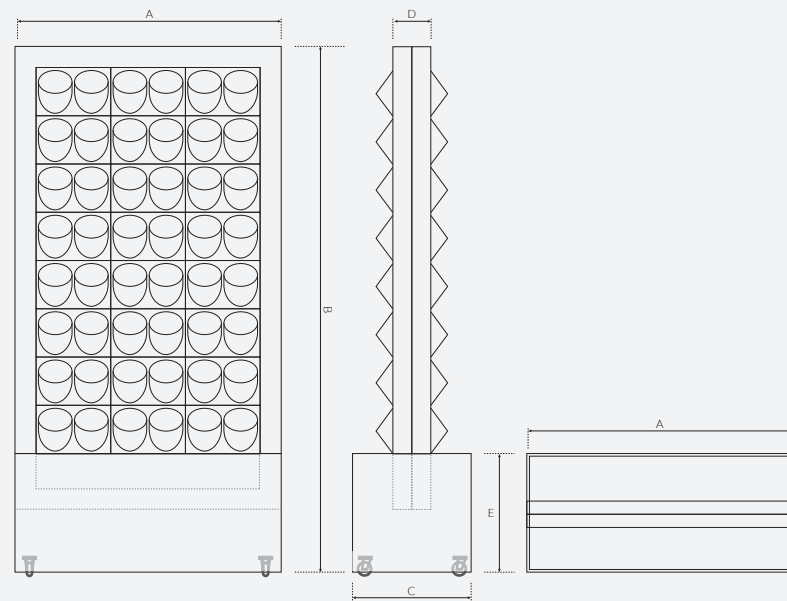

Dimensions

A: 1038 mm B: 2015 mm C: 450 mm D: 200 mm E: 450mm

*dimensions: +/- 3 mm

Specification

stainless steel
aluminium
PP PE

PG14

48 pcs

black | white
black-white mix

125 kg



 **GARDEN**
spot



PREMIUM LINE



PREMIUM Line products are the flagship Garden Spot projects that are synonymous with **high quality**.

Water wall will focus attention in every interior giving it uniqueness coupled with health-promoting properties. Soothing sound of water, humidification of the air and connection with green wall will create atmosphere of calming down and conditions for appropriate work life balance.



more info:
gardenspot.eu/water-green-wall-premium



Refined details

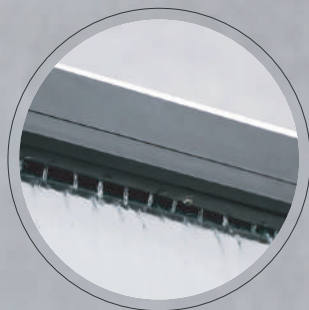

Efficient sprinkler system

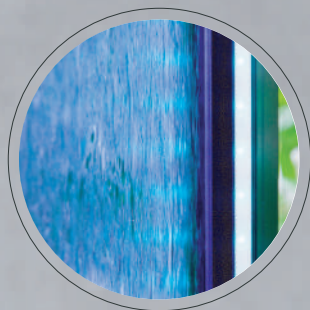

Multicolor LED lighting



Natural stones in two colors



Remote controlled lighting



Hidden mobile wheels

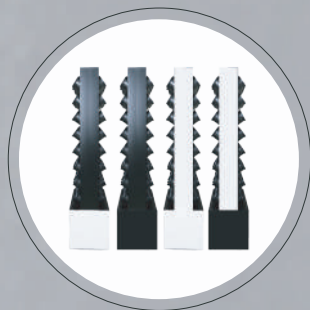

Available in black and white combination



Perfect in combination with a water wall

... Water Wall Premium



70

... PREMIUM LINE

... Technical data

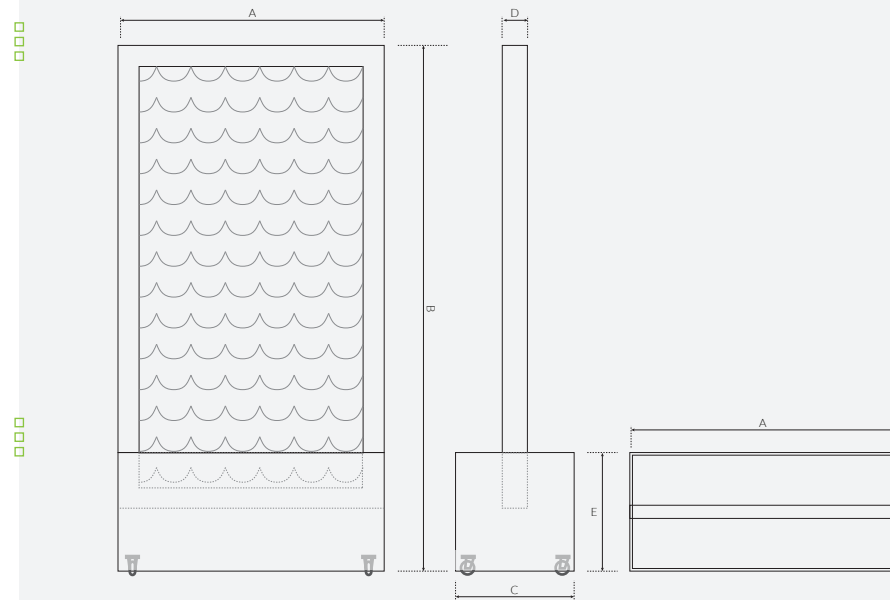







Dimensions

A: 1038 mm B: 2015 mm C: 450 mm D: 50 mm E: 450mm

*dimensions: +/- 3 mm

Specification

-  stainless steel
-  aluminium
-  tempered glass
-  PG14
-  6 pcs
-  black | white
black-white mix
-  96 kg



PREMIUM LINE



 **GARDEN**
spot





WATER FILLING STATION

About Water Filling Station

76

Water Filling Station 35 L

78

Water Filling Station 75 L

80

Water Filling Station 95 L

82



... WATER FILLING STATION

Mobile Filling Station was designed in order to facilitate the irrigation of mobile green walls from Alu Line and Simple Line series.

The device is equipped in a water reservoir and the system of pumps what enables the complete irrigation process of vertical gardens as well as drainage of excess of the water.

76

The device is mobile what makes it easy to move.

Water Filling station is perfect solution when there are a few mobile vertical gardens located in the same building.



more info: gardenspot.eu





... Water filling station 35 L

78



... Technical data

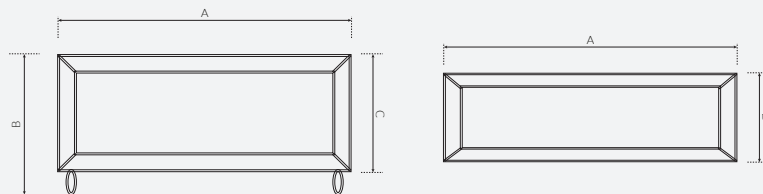

Dimensions

A: 890 mm

B: 420 mm

C: 350 mm

D: 350 mm

*dimensions: +/- 3 mm

Specification



stainless steel
aluminium



35 L



black | white
anthracite



25 kg
(without water)



WATER FILLING STATION

... Water filling station 75 L

80



... Technical data

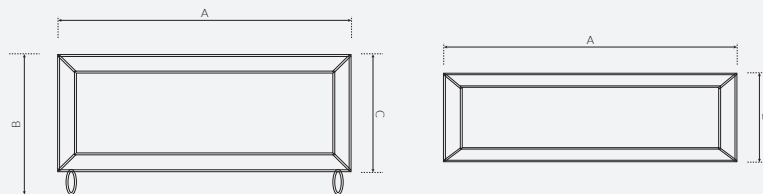

Dimensions

A: 890 mm

B: 580 mm

C: 510 mm

D: 420 mm

*dimensions: +/- 3 mm

Specification



stainless steel
aluminium



75 L



black | white
anthracite



38 kg
(without water)



... Water filling station 95 L

82



... Technical data

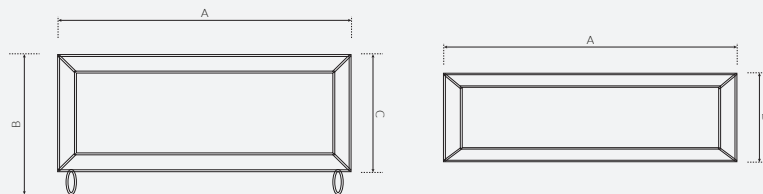

Dimensions

A: 890 mm

B: 680 mm

C: 610 mm

D: 420 mm

*dimensions: +/- 3 mm

Specification



stainless steel
aluminium



95 L



black | white
anthracite



53 kg
(without water)



WATER FILLING STATION





WATER FILLING STATION

MY LITTLE HOME GARDEN



My Little Home Garden idea	100
Hanging vertical frames	102
Standing vertical frames	112



... MY LITTLE HOME GARDEN

My Little Home Garden is a ready-made vegetable garden that you just need to hang on the wall at home or on the balcony.

The product allows you to feel the taste and smell of freshly grown herbs, vegetables and fruits and the built-in overflow irrigation system will make it using it simple and pleasant.

The advantages of the home vegetable garden:

- constant access to fresh vegetables, fruits and herbs
- food self-sufficiency
- own, undemanding, individual production
- products chemical-free from plant protection products
- budget saving
- unique decor of each kitchen

Just fill the top row of pots with water and it will be delivered to the pots below through a special overflow system.



more info:

gardenspot.eu/little-verticals-gardens





... STF1/2PG09/HG | one-sides, hanging frame

102



... Technical data

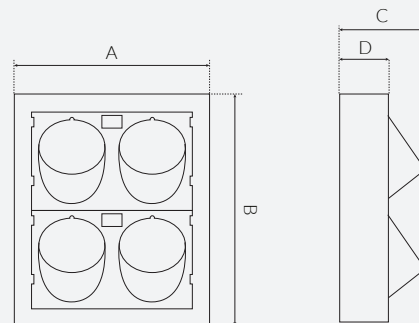

Dimensions

A: 220 mm

B: 267 mm

C: 140 mm

D: 85 mm

*dimensions: +/- 3 mm

Specification

steel | PP PE

PG09

2 pcs

black | white

2,5 kg

Irrigation system

manual



... STF2/3PG09/HG | one-sided, hanging frame



104

... MY LITTLE HOME GARDEN

... Technical data

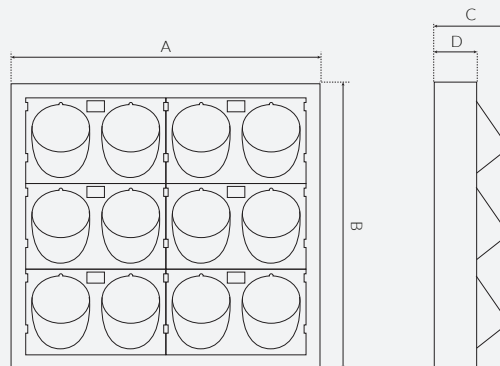

Dimensions

A: 420 mm

B: 390 mm

C: 140 mm

D: 85 mm

*dimensions: +/- 3 mm

Specification



steel | PP PE



PG09



6 pcs



black | white



5 kg

Irrigation system



manual



... STF1/3PG14/HG | one-sided, hanging frame



106

... Technical data

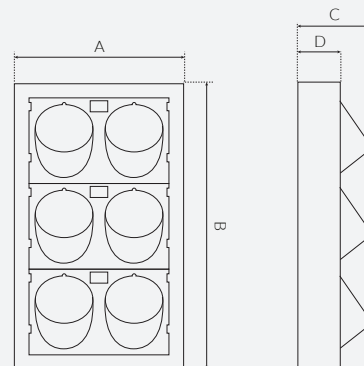

Dimensions

A: 320 mm

B: 585 mm

C: 210 mm

D: 110 mm

*dimensions: +/- 3 mm

Specification



steel | PP PE



PG14



3 pcs



black | white



6 kg

Irrigation system



manual



www.vegi.com

MY LITTLE HOME GARDEN

... STF2/3PG14/HG | one-sided, hanging frame

108



... Technical data

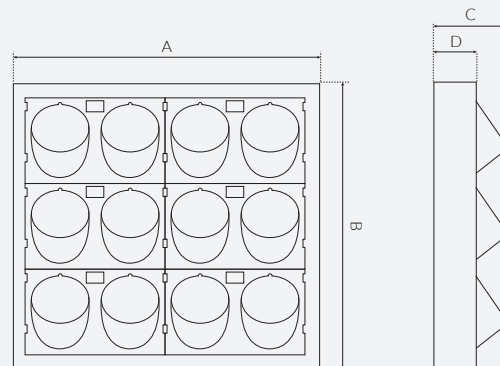

Dimensions

A: 625 mm

B: 585 mm

C: 210 mm

D: 110 mm

*dimensions: +/- 3 mm

Specification



steel | PP PE



PG14



6 pcs



black | white



12 kg

Irrigation system



manual



... STF2/9PG14/HG | one-sided, hanging frame



110

... Technical data

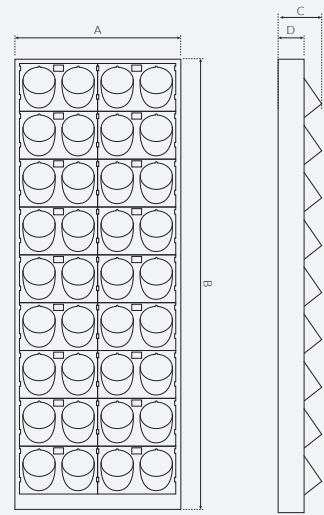

Dimensions

A: 625 mm B: 1740 mm C: 210 mm D: 110 mm *dimensions: +/- 3 mm

Specification

- steel | PP PE
- PG14
- 18 pcs
- black | white
- 40 kg

Irrigation system

- manual



CAPITAL BUILD
ESTATE DEVELOPMENT

... STL2/9PG14/HG | one-sided, standing frame

112



... Technical data

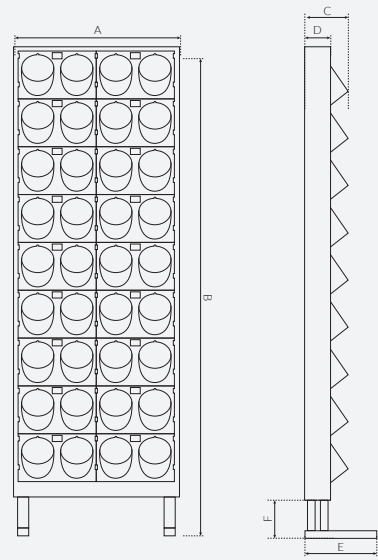





Dimensions



A: 625 mm B: 1910 mm C: 210 mm D: 115 mm E: 320 mm F: 120 mm

Specification

*dimensions: +/- 3 mm

-  steel | PP PE
-  PG14
-  18 pcs
-  black | white
-  40 kg

Irrigation system

-  manual
-  garden hose









DECORATIVE POTS

Decorative pots

106

Offer of pots

108



... DECORATIVE POTS

The highest quality handmade **flower pots**.

We present handmade pots in excellent workmanship. The design have been developed by experienced and creative artists, inspired by the idea of biophilic design.

The concept of biophilic design is a relatively recent trend, which is gaining popularity all over the world. Its main assumption is to create a working or living environment in the manner referring to nature.

Such solutions are particularly important in large cities, where progressive urbanization deprives residents of green areas. Our exclusive pots made of natural materials fit perfectly into this trend.



more info: gardenspot.eu/decorative-pots





... Decorative pots



90



Aestian Oval



steel



indoor

Dimensions



55 cm



47 cm



30 cm



15 cm



40 cm



Udedom Vase Medium



steel



indoor

Dimensions



44 cm



39 cm



90 cm



35 cm

Udedom Vase Large



steel



indoor

Dimensions



55 cm

Inside dimensions



46 cm



110 cm



35 cm

Udedom Round Bowl



steel



indoor

Dimensions



50 cm

Inside dimensions



23 cm



40 cm



36 cm



... Decorative pots



92



Volin Round Bowl



steel



indoor

Dimensions



58 cm



18 cm



31 cm



28 cm

Inside dimensions

Volin Vase



steel



indoor

Dimensions



48 cm



25 cm



116 cm



110 cm

Inside dimensions

Fasta Vase



steel



indoor

Dimensions



47 cm



37 cm



81 cm



65 cm

Inside dimensions

Fasta Round Bowl



steel



indoor

Dimensions



70 cm



48 cm



30 cm

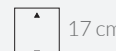

17 cm

Inside dimensions



... Decorative pots



94



Lavida Vase Small



steel



indoor

Dimensions



39 cm



37 cm



75 cm



35 cm

Inside dimensions

Lavida Vase Medium



steel



indoor

Dimensions



46 cm



44 cm



90 cm



35 cm

Inside dimensions

Lavida Vase Large



steel



indoor

Dimensions



57 cm



55 cm



120 cm



40 cm

Inside dimensions

Lavida Round Bowl Small



steel



indoor

Dimensions



50 cm



28 cm



40 cm



40 cm

Inside dimensions



... Decorative pots



96



Lavida Saucer Small



steel



indoor

Dimensions



60 cm



26 cm



15 cm



13 cm

Inside dimensions

Lavida Saucer Large



steel



indoor

Dimensions



75 cm



34 cm



15 cm



13 cm

Inside dimensions

Lavida Bowl



steel



indoor

Dimensions



43 cm



42 cm



22 cm



21 cm

Inside dimensions

Lavida Oval Small



steel



indoor

Dimensions



75 cm



73 cm



26,5 cm



26,5 cm

Inside dimensions



26,5 cm



26,5 cm





ACOUSTIC BOXES

Acoustic boxes idea	118
1 person boxes	120
2-3 person boxes	122
6 person boxes	124



... ACOUSTIC BOXES

Acoustic boxes are perfect solution as a form of asylum for temporary rest and at the same time a place for conducting a briefing or conferences. The boxes are available in option for 1, 2/3 or 6 people.

Acoustic box filled with the greenery allows its users to minimize the negative impact of pollution on the human's health and to improve the living conditions and comfort.

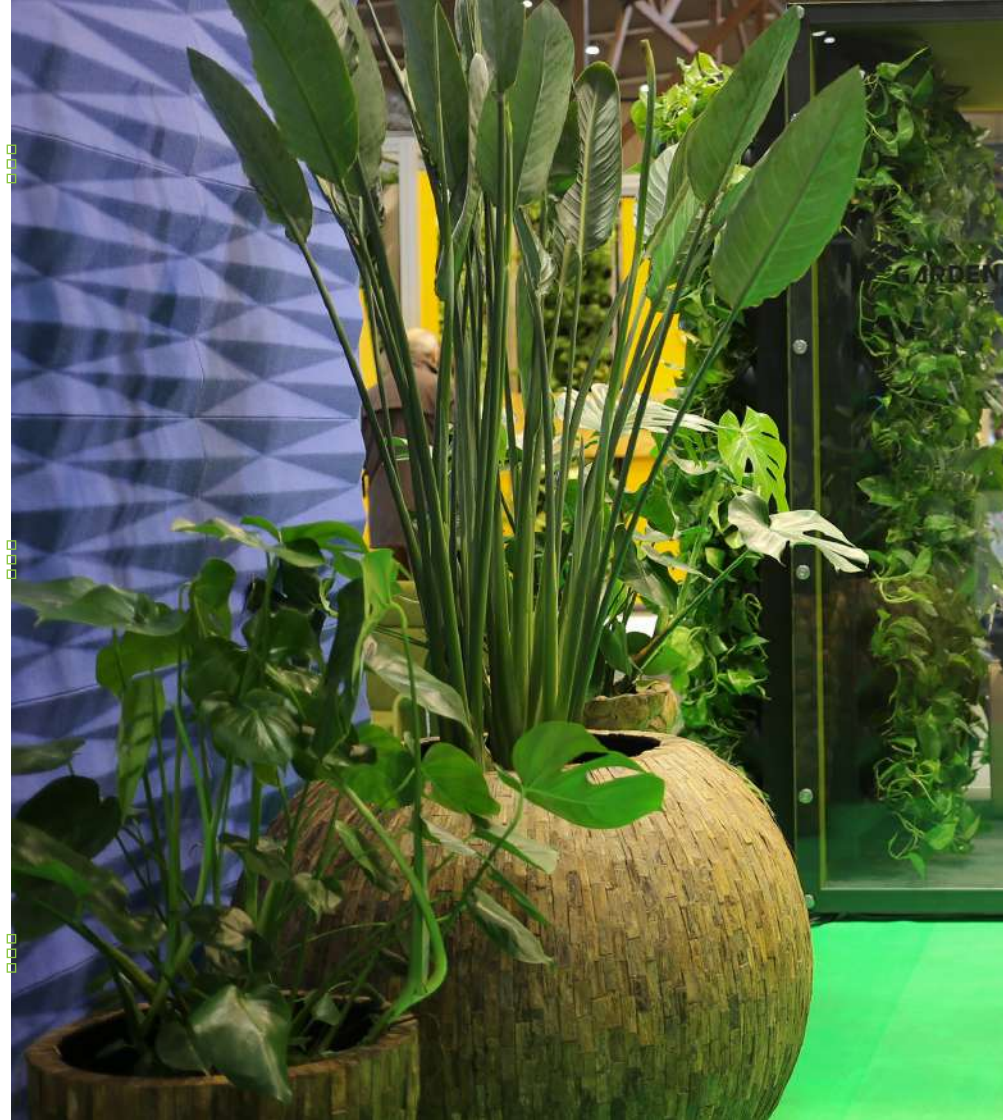



- BIOPHILIC DESIGN
- SOFT SOUNDPROOFING
- ADJUSTABLE LED LIGHTING
- QUALITY AND EFFICIENT VENTILATION
- USB + USB CHARGER SOCKET
- MODULAR ARRANGIBLE
- DIETED SYSTEM FOR BICHARD
- AIR QUALITY SENSOR
- LIGHT LEVEL SENSOR
- NOISE LEVEL SENSOR

ACOUSTIC BOXES ...

A few minutes in the green relaxation zone immediately improves the level of well-being and reduces stress what increases the efficiency of employees.

The walls of the box are upholstered with fabrics with acoustic properties. The sound is also insulated by glass with high phonic parameters and by natural, living plants in the Pixel Garden vertical gardens with an integrated irrigation system.



more info: gardenspot.eu/green-acoustic-boxes

... Biophilia Box 1P.A | 1 person option

120



Modular system Pixel Garden with living, natural greenery is installed on the chosen, internal or external walls of the acoustic boxes.

... ACOUSTIC BOXES

... Technical data

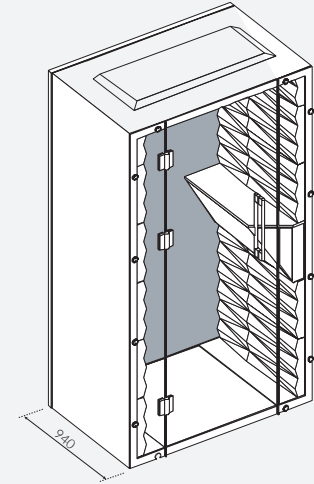
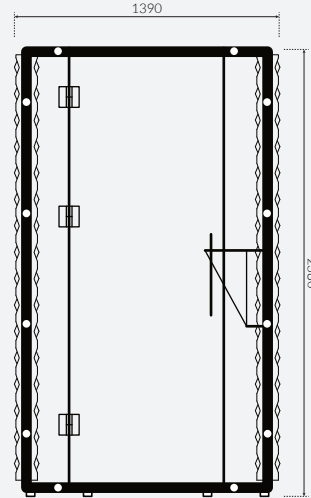

Specification

- free standing upholstered pod for 1-person
 - featuring door made of safety glass
 - side walls with diamond pattern inside, smooth upholstered back wall
 - floor covering
- Equipment:
- lighting and ventilation with a motion detector
 - connection panel: 1x 230 V + 2x USB (charger) in an upholstered shelf with a SwissCDF top in graphite colour height 115 cm
 - option: different color of upholstery inside (box body and upholstered shelf sides, and back wall) and outside (box body and back wall) within one kind of fabric

Biophilia Box 1P.B

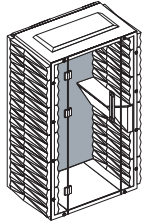

SPECIFICATION:

- free standing upholstered pod for 1 person
- featuring door made of safety glass
- two-sidedly diamond patterned side walls, smooth upholstered back wall
- floor covering

Equipment:

- lighting and ventilation with a motion detector
- connection panel: 1x 230 V + 2x USB (charger) in an upholstered shelf with a SwissCDF top in graphite colour height 115 cm
- option: different color of upholstery inside (box body and upholstered shelf sides, and back wall) and outside (box body and back wall) within one kind of fabric

Biophilia Box 1P.C

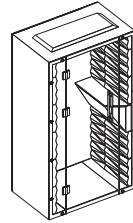

SPECIFICATION:

- free standing upholstered pod for 1 person
- featuring door made of safety glass
- side walls with diamond pattern inside, back wall made of glass
- floor covering

Equipment:

- lighting and ventilation with a motion detector
- connection panel: 1x 230 V + 2x USB (charger) in an upholstered shelf with a SwissCDF top in graphite colour height 115 cm
- option: different color of upholstery inside (box body and upholstered shelf sides, and back wall) and outside (box body and back wall) within one kind of fabric.

Biophilia Box 1P.D

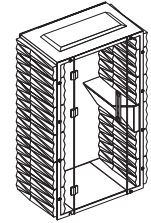

SPECIFICATION:

- free standing upholstered pod for 1 person
- featuring door made of safety glass
- two-sidedly diamond patterned side walls, back wall made of glass
- floor covering

Equipment:

- lighting and ventilation with a motion detector
- connection panel: 1x 230 V + 2x USB (charger) in an upholstered shelf with a SwissCDF top in graphite colour height 115 cm
- option: different color of upholstery inside (box body and upholstered shelf sides, and back wall) and outside (box body and back wall) within one kind of fabric.

... Biophilia Box 2P.A | 2/3 people

122



Modular system Pixel Garden with living, natural greenery is installed on the chosen, internal or external walls of the acoustic boxes.

... ACOUSTIC BOXES

... Technical data

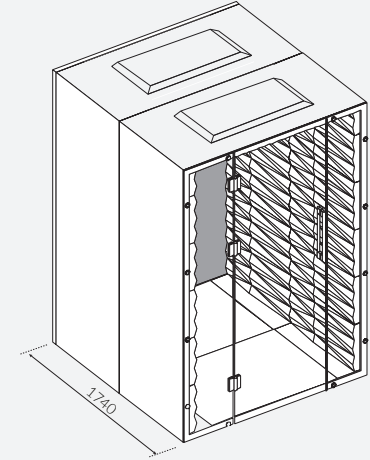
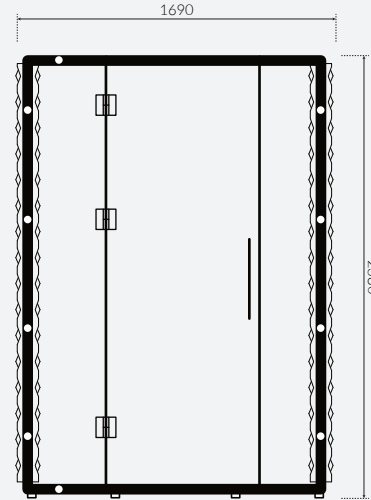

Specification

- free standing upholstered pod for 2-3 persons
 - featuring door made of safety glass
 - with diamond pattern inside, smooth upholstered back wall
 - floor covering
- Equipment:
- lighting and ventilation with a 4-field touch pad PA-4
 - connection panel: 2x 230 V + 2x USB (charger)
 - option: different color of upholstery inside (box body, and back wall) and outside (box body and back wall) within one kind of fabric

Biophilia Box 2P.B

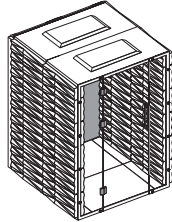

SPECIFICATION:

- free standing upholstered pod for 2-3 persons
- featuring door made of safety glass
- two-sidedly diamond-patterned side walls, smooth upholstered back wall
- floor covering

Equipment:

- lighting and ventilation with a 4-field touch pad PA-4
- connection panel: 2x 230 V + 2x USB (charger)
- option: different color of upholstery inside (box body, and back wall) and outside (box body and back wall) within one kind of fabric

Biophilia Box 2P.C

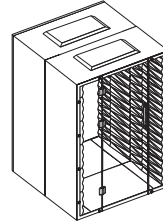

SPECIFICATION:

- free standing upholstered pod for 2-3 persons
- featuring door made of safety glass
- with diamond pattern inside, back wall made of glass
- floor covering

Equipment:

- lighting and ventilation with a 4-field touch pad PA-4
- connection panel: 2x 230 V + 2x USB (charger)
- option: different color of upholstery inside (box body, and back wall) and outside (box body and back wall) within one kind of fabric

Biophilia Box 2P.D

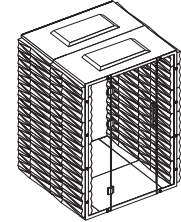

SPECIFICATION:

- free standing upholstered pod for 2-3 persons
- featuring door made of safety glass
- two-sidedly diamond-patterned side walls, back wall made of glass
- floor covering

Equipment:

- lighting and ventilation with a 4-field touch pad PA-4
- connection panel: 2x 230 V + 2x USB (charger)
- option: different color of upholstery inside (box body, and back wall) and outside (box body and back wall) within one kind of fabric

... Biophilia Box 3P.A | 6 people



Modular system Pixel Garden with living, natural greenery is installed on the chosen, internal or external walls of the acoustic boxes.

... ACOUSTIC BOXES

... Technical data

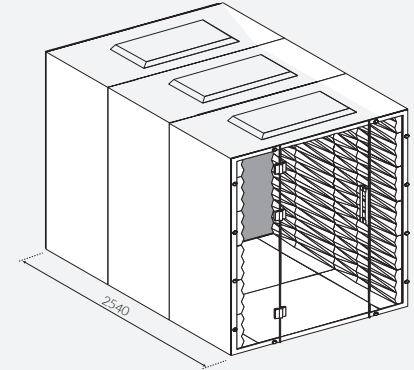
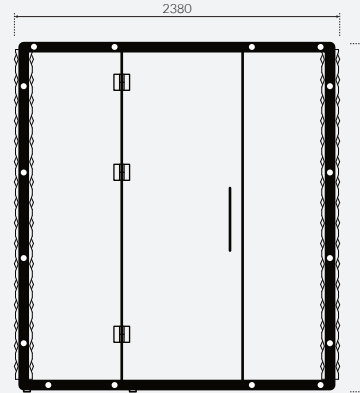

Specification

- free standing upholstered pod for 6 persons
 - featuring door made of safety glass
 - with diamond pattern inside, smooth upholstered back wall
 - floor covering
- Equipment:
- lighting and ventilation with a 4-field touch pad PA-4
 - connection panel: 2x 230 V + 2x USB (charger)
 - option: different color of upholstery inside (box body, and back wall) and outside (box body and back wall) within one kind of fabric
 - option of equipment with a set of seats and table TS-6 (extra charge)

Biophilia Box 3P.B

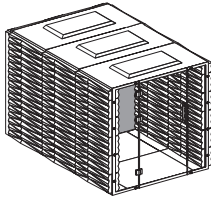

SPECIFICATION:

- free standing upholstered pod for 6 persons
- featuring door made of safety glass
- two-sidedly diamond patterned side walls, smooth upholstered back wall
- floor covering

Equipment:

- lighting and ventilation with a 4-field touch pad PA-4
- connection panel: 2x 230 V + 2x USB (charger)
- option: different color of upholstery inside (box body, and back wall) and outside (box body and back wall) within one kind of fabric
- option of equipment with a set of seats and table TS-6 (extra charge)

Biophilia Box 3P.C

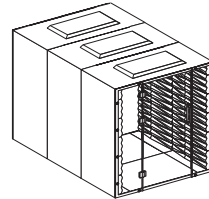

SPECIFICATION:

- free standing upholstered pod for 6 persons
- featuring door made of safety glass
- side walls with diamond pattern inside, back wall made of glass
- floor covering

Equipment:

- lighting and ventilation with a 4-field touch pad PA-4
- connection panel: 2x 230 V + 2x USB (charger)
- option: different color of upholstery inside (box body, and back wall) and outside (box body and back wall) within one kind of fabric
- option of equipment with a set of seats and table TS-6 (extra charge)

Biophilia Box 3P.D

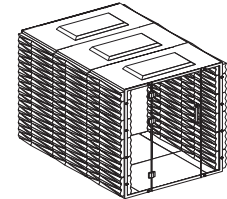

SPECIFICATION:

- free standing upholstered pod for 6 persons
- featuring door made of safety glass
- two-sidedly diamond patterned side walls, back wall made of glass
- floor covering

Equipment:

- lighting and ventilation with a 4-field touch pad PA-4
- connection panel: 2x 230 V + 2x USB (charger)
- option: different color of upholstery inside (box body, and back wall) and outside (box body and back wall) within one kind of fabric
- option of equipment with a set of seats and table TS-6 (extra charge)

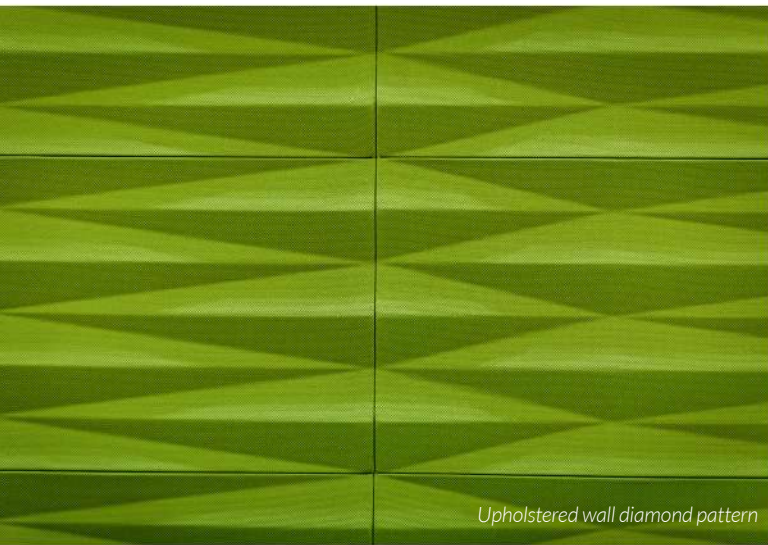

Upholstered wall diamond pattern



Detail and high-quality finishes





Original LED lighting with air pollution sensor

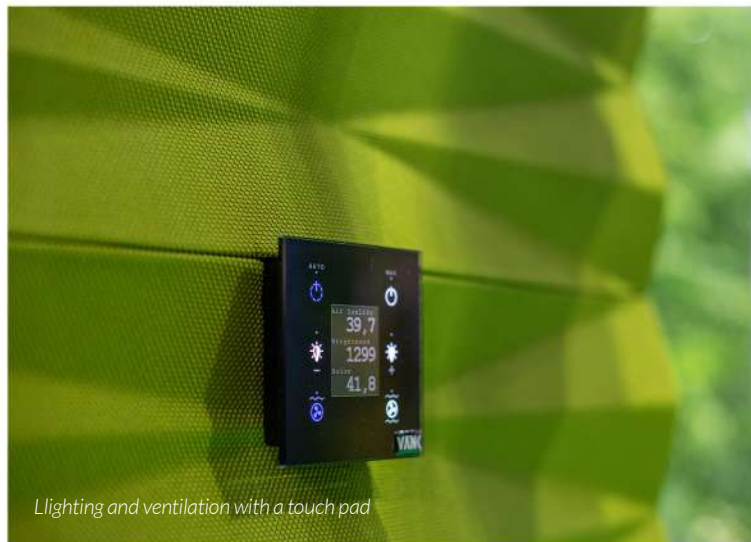

Lighting and ventilation with a touch pad





ACOUSTIC BOXES

- ORGANIC MATERIAL
- GOOD SOUNDPROOFING
- ADJUSTABLE LED LIGHTING
- QUIET AND EFFICIENT VENTILATION
- 230V + USB CHARGER SOCKET
- MODULAR ASSEMBLY
- AIR QUALITY SENSOR
- LIGHT LEVEL SENSOR
- NOISE LEVEL SENSOR







LAWN LATTICE

Lawn lattice idea	134
Garden Grid 2.0	136
Parking marker	137
Anchor	138

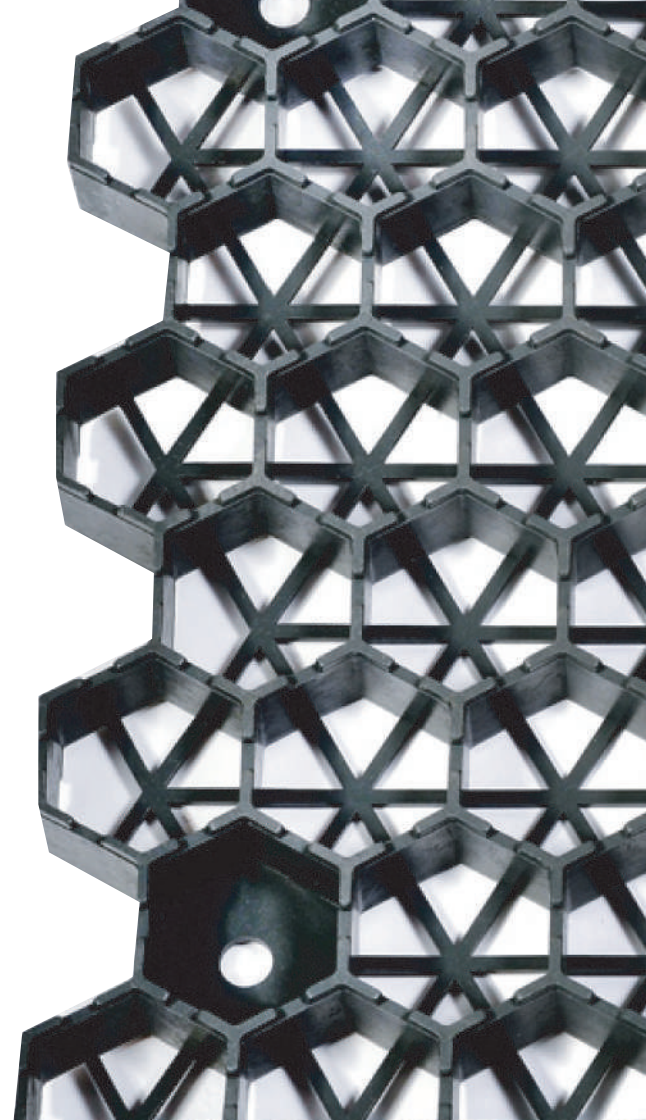

... **LAWN LATTICE**

Garden Grid lawn lattice is environmentally friendly product manufactured from recycled materials. It is an alternative to standard ground stabilization methods such as paving stones or open-work slabs. Due to the high quality and excellent strength parameters, Garden Grid is used primarily in construction, gardening and transport.

134 The compact structure of the Garden Grid ensures high load resistance and resistance to deformation under high pressure (even up to 350 t/m²).





LAWN LATTICE ...

An additional advantage is the optional anchoring system that allows the GG to be mounted on slopes, also these with a high angle of inclination, and very good drainage properties that allow rainwater to freely penetrate into the ground - the biologically active area is 86.6%.

We own the certificate in terms of production of plastic products ISO 9001: 2015.



more info: gardenspot.eu/lawn-lattice

... Garden Grid 4.2

136



... Technical data

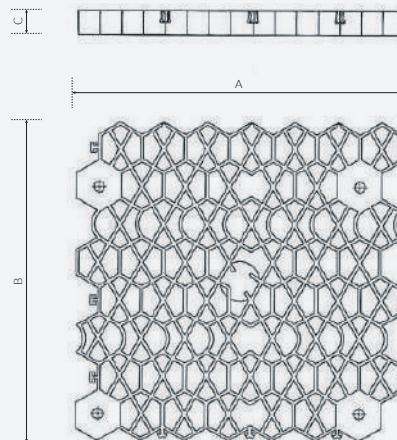

Dimensions

A: 537 mm B: 521 mm C: 400 mm

Specification

PP PE | HD PE

350 t/m²

black



1,4 kg

Durability in ground: over 25 years

■ ■ ■ Parking mark

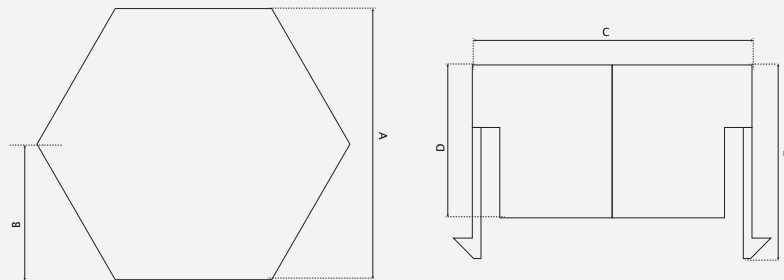

■ ■ ■ Technical data



Dimensions

A: 62 mm

B: 35 mm

C: 62 mm

D: 33 mm

E: 42 mm

Specification



PE



black



0,05 kg

Anchor



138

Technical data

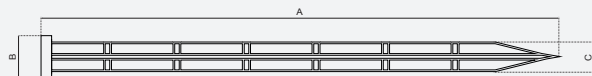

Dimensions

A: 255 mm B: 21 mm C: 15 mm

Specification



PE



black



0,05 kg







